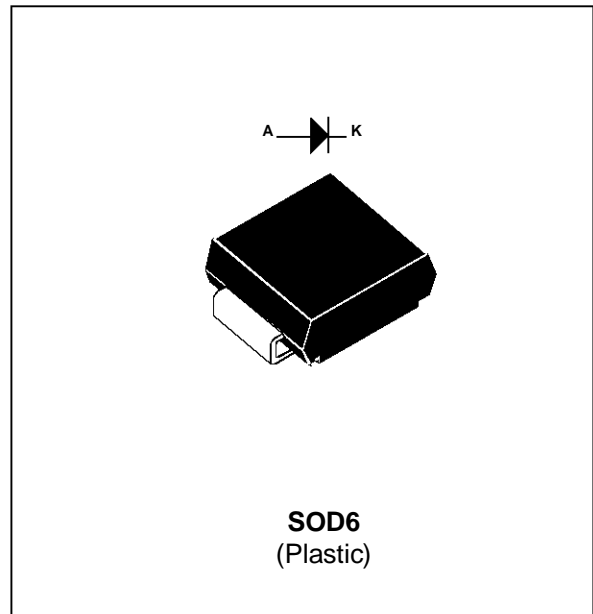


**TURBOSWITCH™ "A". ULTRA-FAST HIGH VOLTAGE DIODE**
**MAIN PRODUCTS CHARACTERISTICS**

<b>I<sub>F(AV)</sub></b>	<b>1A</b>
<b>V<sub>RRM</sub></b>	<b>1200V</b>
<b>t<sub>rr</sub> (typ)</b>	<b>65ns</b>
<b>V<sub>F</sub> (max)</b>	<b>1.5V</b>

**FEATURES AND BENEFITS**

- SPECIFIC TO "FREEWHEEL MODE" OPERATIONS: FREEWHEEL OR BOOSTER DIODE
- ULTRA-FAST AND SOFT RECOVERY
- VERY LOW OVERALL POWER LOSSES IN BOTH THE DIODE AND THE COMPANION TRANSISTOR
- HIGH FREQUENCY OPERATIONS
- SURFACE MOUNT DEVICE


**DESCRIPTION**

The TURBOSWITCH is a very high performance series of ultra-fast high voltage power diodes from 600V to 1200V. TURBOSWITCH 1200V drastically cuts losses in all high voltage operations which require extremely fast, soft and noise-free power diodes.

Due to their optimized switching performances they also highly decrease power losses in any associated switching IGBT or MOSFET in all

"Freewheel Mode" operations.

They are particularly suitable in Motor Control circuitries, or in primary of SMPS as snubber, clamping or demagnetizing diodes, and also in at the secondary of SMPS as high voltage rectifier diodes.

Packaged in SOD6 surface mount envelope, these 1200V devices are particularly intended for use on 3 phase 400V industrial mains.

**ABSOLUTE MAXIMUM RATINGS**

<b>Symbol</b>	<b>Parameter</b>	<b>Value</b>	<b>Unit</b>
V <sub>RRM</sub>	Repetitive Peak Reverse Voltage	1200	V
V <sub>RSM</sub>	Non Repetitive Peak Reverse Voltage	1200	V
I <sub>F(RMS)</sub>	RMS Forward Current	3.5	A
I <sub>FRM</sub>	Repetitive Peak Forward Current (tp = 5 μs, f = 5kHz)	22	A
T <sub>j</sub>	Max. Operating Junction Temperature	125	°C
T <sub>stg</sub>	Storage Temperature range	- 65 to + 150	°C

## STTA112U

### THERMAL AND POWER DATA

Symbol	Parameter	Conditions	Value	Unit
$R_{th(j-l)}$	Junction to Lead Thermal Resistance		23	°C/W
$P_1$	Conduction Power Dissipation (see fig. 6)	$I_{F(AV)} = 0.8A$ $\delta = 0.5$ $T_{lead} = 93^\circ C$	1.4	W
$P_{max}$	Total Power Dissipation $P_{max} = P_1 + P_3$ ( $P_3 = 10\% P_1$ )	$T_{lead} = 90^\circ C$	1.5	W

### STATIC ELECTRICAL CHARACTERISTICS (see Fig. 6)

Symbol	Parameter	Test Conditions	Min	Typ	Max	Unit
$V_F$ *	Forward Voltage Drop	$I_F = 1A$ $T_j = 25^\circ C$ $T_j = 125^\circ C$		1.1	1.66 1.5	V
$I_R$ **	Reverse Leakage Current	$V_R = 0.8$ $\times V_{RRM}$ $T_j = 25^\circ C$ $T_j = 125^\circ C$		90	10 300	$\mu A$

Test pulses widths : \*  $t_p = 380 \mu s$ , duty cycle < 2%

\*\*  $t_p = 5 ms$ , duty cycle < 2%

### DYNAMIC ELECTRICAL CHARACTERISTICS

#### TURN-OFF SWITCHING (see Fig. 7)

Symbol	Parameter	Test Conditions	Min	Typ	Max	Unit
$t_{rr}$	Reverse Recovery Time	$T_j = 25^\circ C$ $I_F = 0.5 A$ $I_R = 1A$ $I_{rr} = 0.25A$ $I_F = 1 A$ $di_F/dt = -50A/\mu s$ $V_R = 30V$		65	115	ns
$I_{RM}$	Maximum Recovery Current	$T_j = 125^\circ C$ $V_R = 600V$ $I_F = 1A$ $di_F/dt = -8 A/\mu s$ $di_F/dt = -50 A/\mu s$		5	1.8	A
S factor	Softness factor	$T_j = 125^\circ C$ $V_R = 600V$ $I_F = 1A$ $di_F/dt = -50 A/\mu s$		0.7		/

#### TURN-ON SWITCHING (see Fig. 8)

Symbol	Parameter	Test Conditions	Min	Typ	Max	Unit
$t_{fr}$	Forward Recovery Time	$T_j = 25^\circ C$ $I_F = 1 A$ , $di_F/dt = 8 A/\mu s$ measured at, $1.1 \times V_F$ max			900	ns
$V_{Fp}$	Peak Forward Voltage				35	V

## APPLICATION DATA

The 1200V TURBOSWITCH™ series has been designed to provide the lowest overall power losses in all frequency or high pulsed current operations.

In such application (fig. 1 to 5), the way of calculating the power losses is given below :

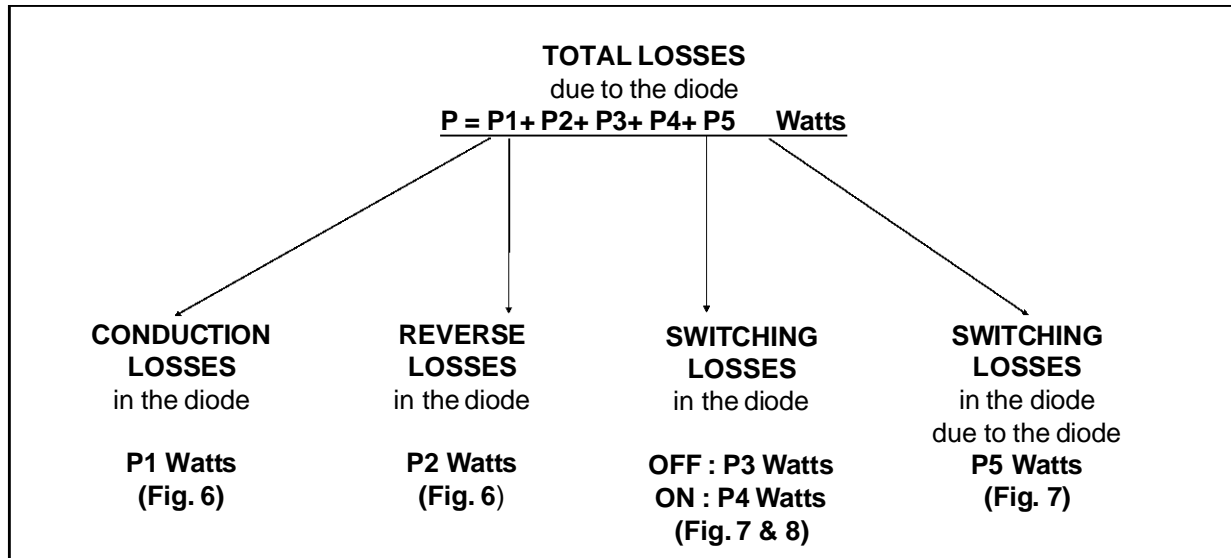
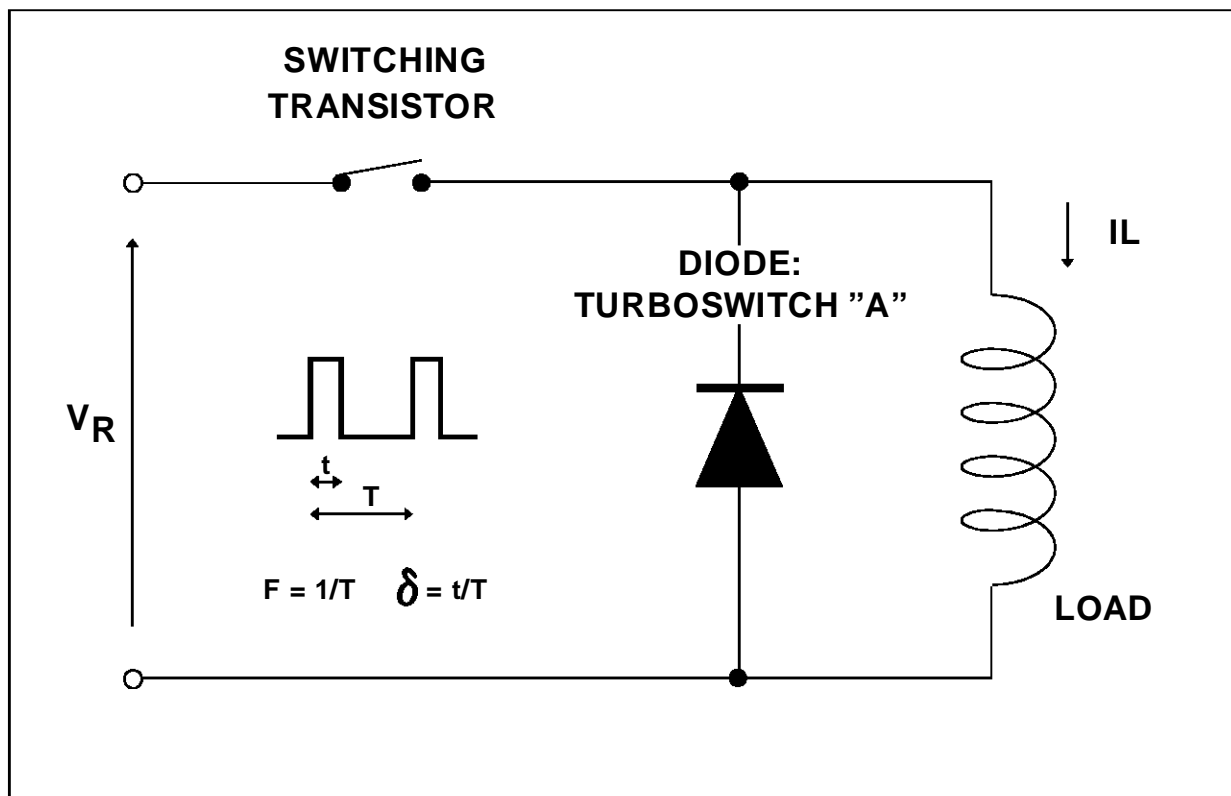


Fig. 1 : "FREEWHEEL MODE".



APPLICATION DATA (Cont'd)

Fig. 2 : SNUBBER DIODE.

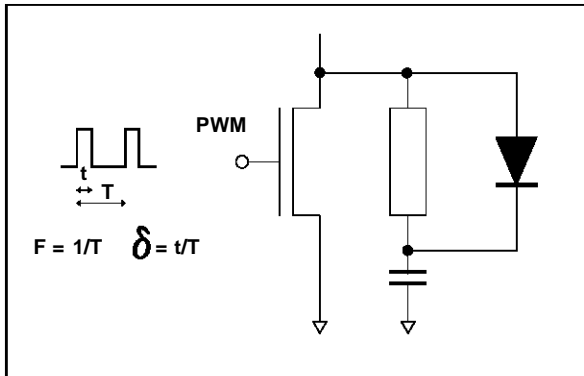


Fig. 3 : CLAMPING DIODE.

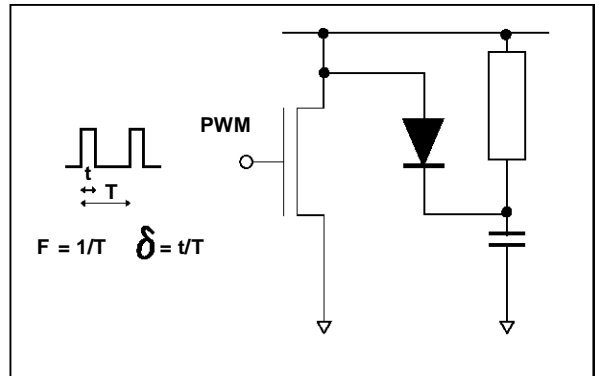


Fig. 4 : DEMAGNETIZING DIODE.

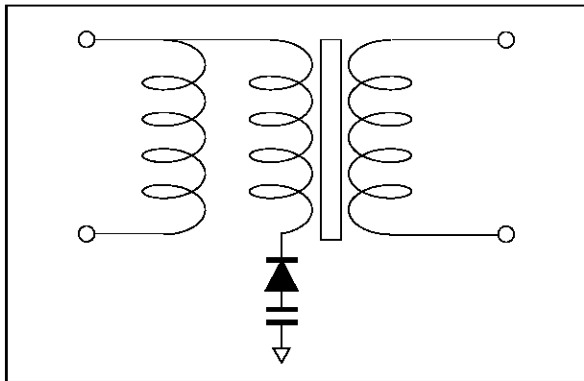


Fig. 5 : RECTIFIER DIODE.

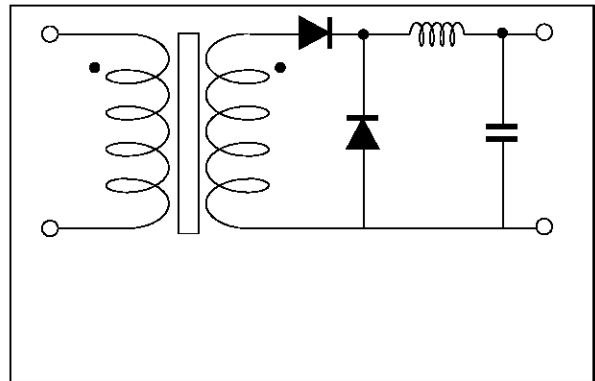
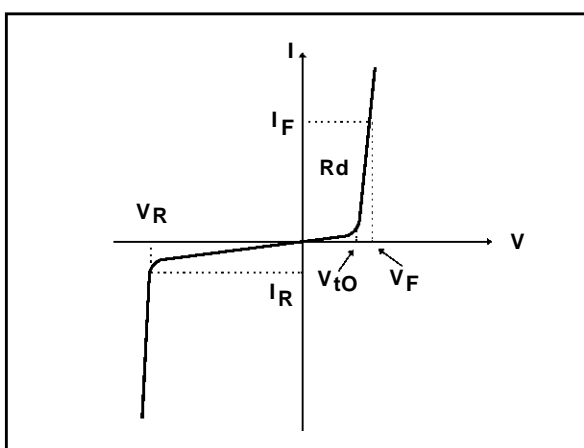


Fig. 6 : STATIC CHARACTERISTICS.



Conduction losses :

$$P1 = V_{t0} \times I_F(AV) + R_d \times I_F^2(RMS)$$

with

$$V_{t0} = 1.15 \text{ V}$$

$$R_d = 0.350 \text{ Ohm}$$

(Max values at 125°C)

Reverse losses :

$$P2 = V_R \times I_R \times (1 - \delta)$$

APPLICATION DATA (Cont'd)

Fig. 7 : TURN-OFF CHARACTERISTICS.

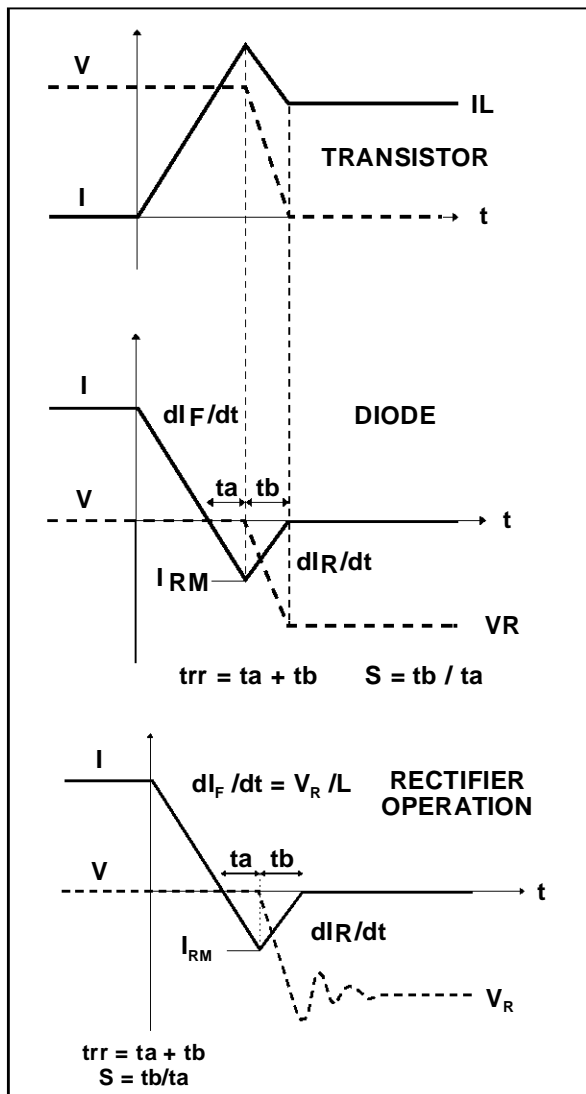
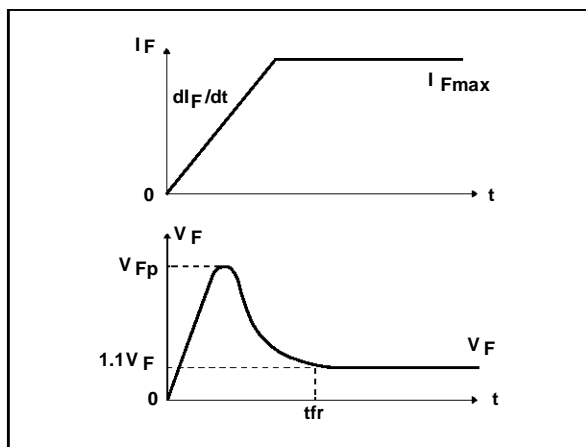


Fig. 8 : TURN-ON CHARACTERISTICS.



Ratings and characteristics curves are ON GOING.

Turn-on losses :  
(in the transistor, due to the diode)

$$P5 = \frac{V_R \times I_{RM}^2 \times (3+2 \times S) F}{6 \times dI_F/dt} + \frac{V_R \times I_{RM} \times I_L \times (S+2) \times F}{2 \times dI_F/dt}$$

Turn-off losses :

$$P3 = \frac{V_R \times I_{RM}^2 \times S \times F}{6 \times dI_F/dt}$$

Turn-off losses :  
with non negligible serial inductance

$$P3' = \frac{V_R \times I_{RM}^2 \times S \times F \times L \times I_{RM}^2 \times F}{6 \times dI_F/dt + 2}$$

P3, P3' and P5 are suitable for power MOSFET and IGBT

Turn-on losses :  
 $P4 = 0.4 (V_{FP} - V_F) \times I_{Fmax} \times t_{fr} \times F$

Fig. 9 : Conduction losses versus average current.

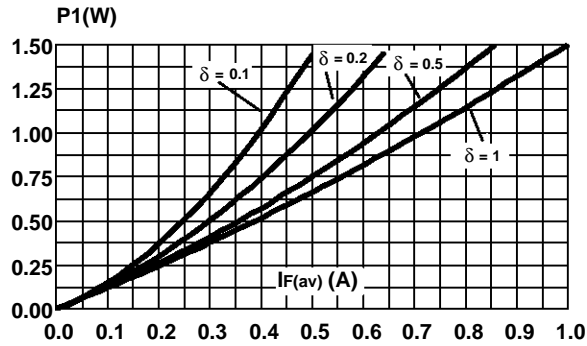


Fig. 10 : Switching OFF losses versus  $di_F/dt$ .

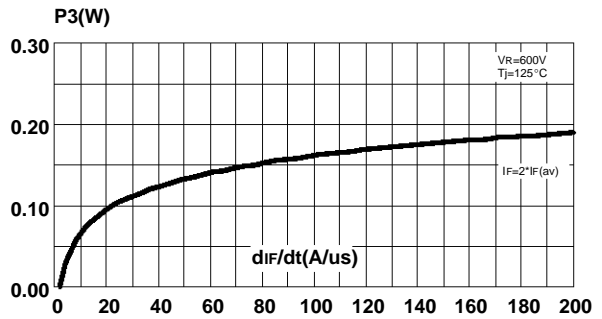


Fig. 11 : Switching ON losses versus  $di_F/dt$ .

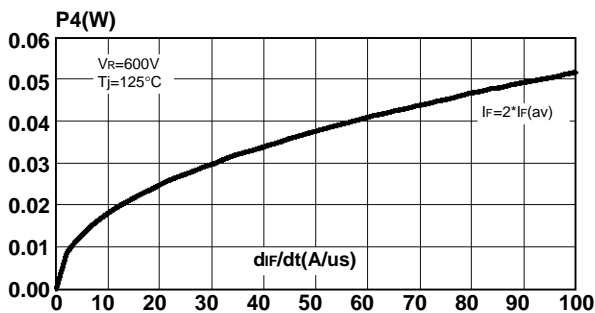


Fig. 12 : Switching losses in transistor due to the diode.

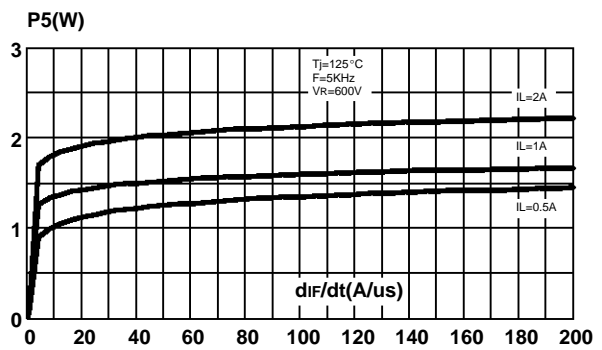


Fig. 13 : Forward voltage drop versus forward current (Maximum values).

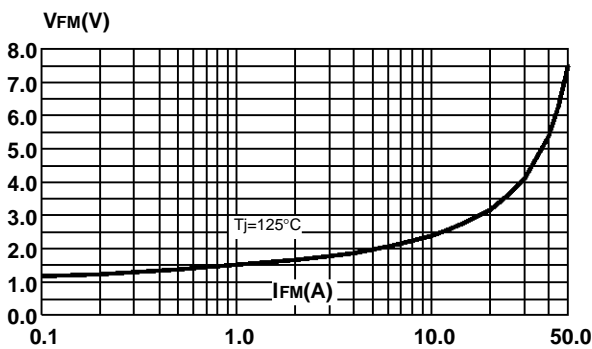
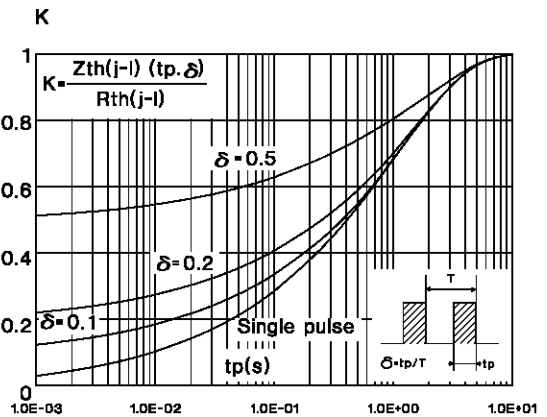
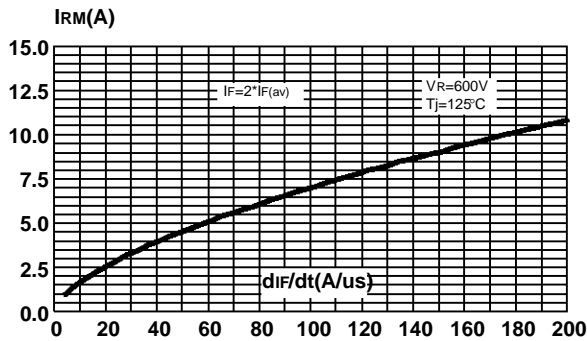


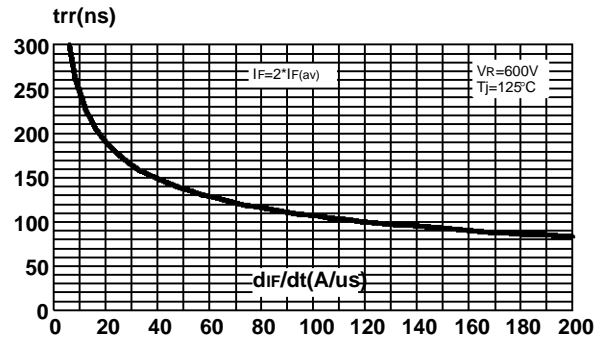
Fig. 14 : Relative variation of thermal transient impedance junction to lead versus pulse duration.



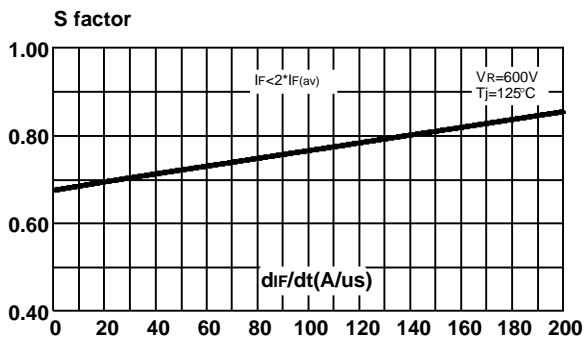
**Fig. 15 :** Peak reverse recovery current versus  $di_F/dt$  (90% confidence).



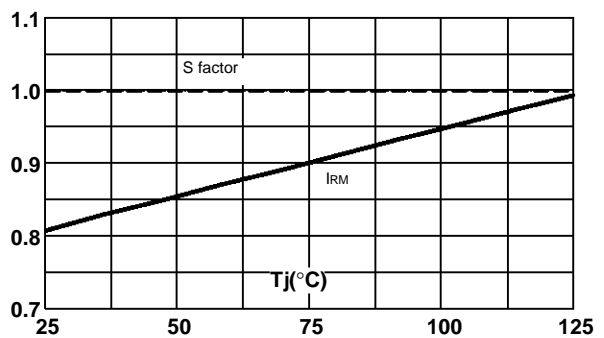
**Fig. 16 :** Reverse recovery time versus  $di_F/dt$  (90% confidence).



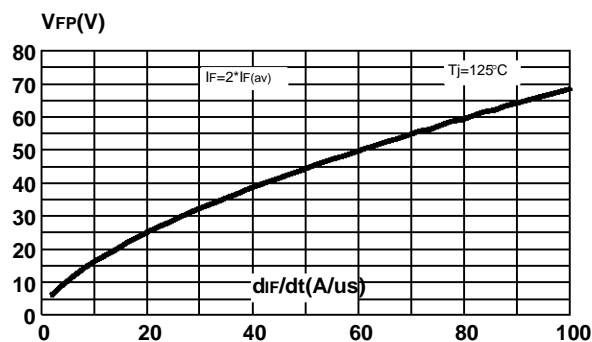
**Fig. 17 :** Softness factor ( $t_b/t_a$ ) versus  $di_F/dt$  (Typical values).



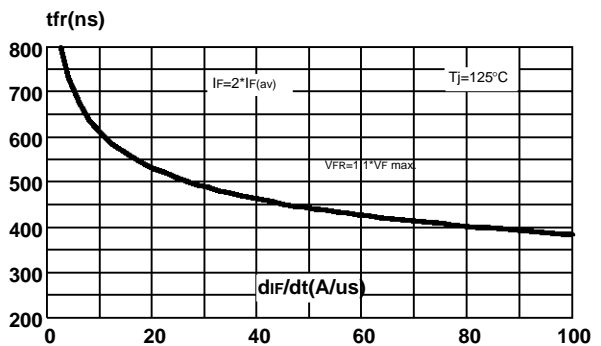
**Fig. 18 :** Relative variation of dynamic parameters versus junction temperature (Reference  $T_j=125^\circ\text{C}$ ).



**Fig. 19 :** Transient peak forward voltage versus  $di_F/dt$  (90% confidence).

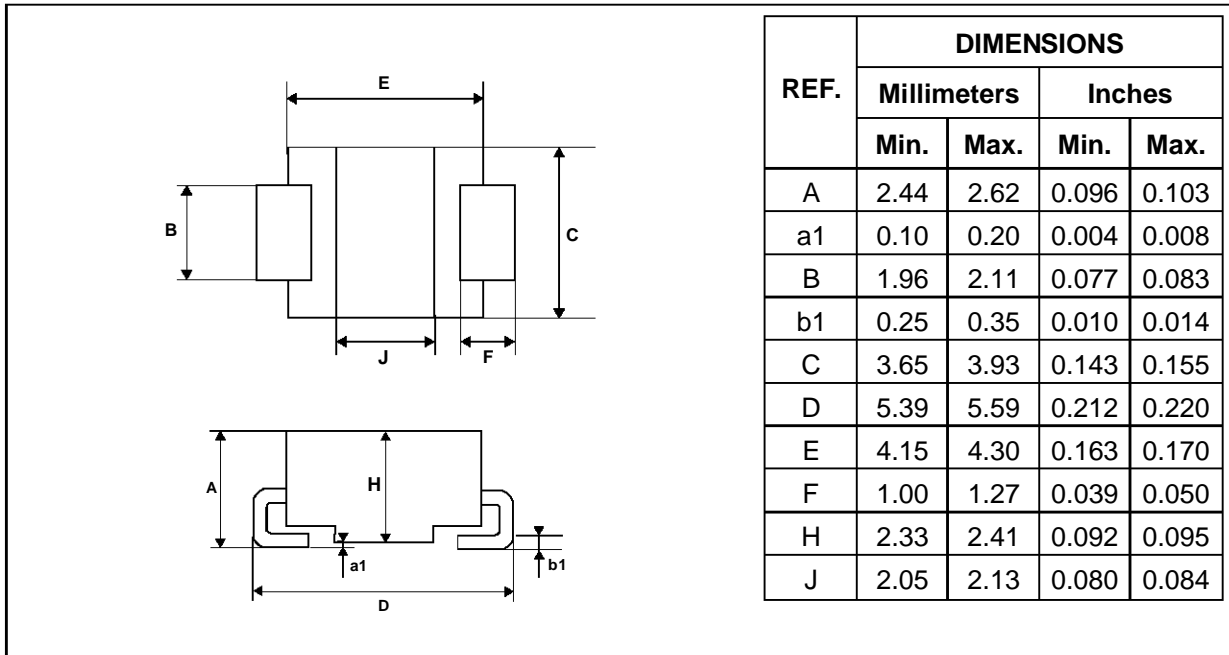


**Fig. 20 :** Forward recovery time versus  $di_F/dt$  (90% confidence).

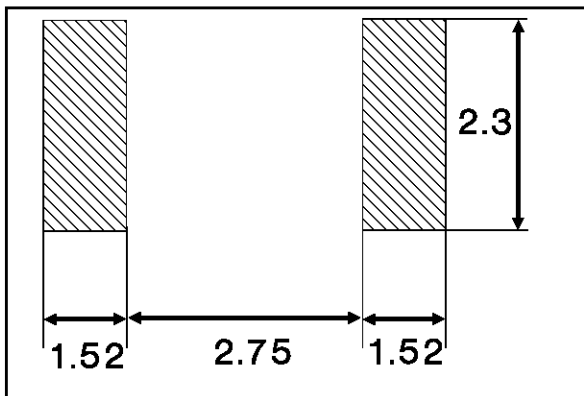


# STTA112U

## PACKAGE MECHANICAL DATA SOD6 Plastic (JEDEC outline)



## FOOTPRINT DIMENSIONS SOD6 Plastic



Marking : T03  
Laser marking  
Logo indicates cathode

Information furnished is believed to be accurate and reliable. However, SGS-THOMSON Microelectronics assumes no responsibility for the consequences of use of such information nor for any infringement of patents or other rights of third parties which may result from its use. No license is granted by implication or otherwise under any patent or patent rights of SGS-THOMSON Microelectronics. Specifications mentioned in this publication are subject to change without notice. This publication supersedes and replaces all information previously supplied. SGS-THOMSON Microelectronics products are not authorized for use as critical components in life support devices or systems without express written approval of SGS-THOMSON Microelectronics.

© 1995 SGS-THOMSON Microelectronics - Printed in Italy - All rights reserved.

SGS-THOMSON Microelectronics GROUP OF COMPANIES

Australia - Brazil - France - Germany - Hong Kong - Italy - Japan - Korea - Malaysia - Malta - Morocco - The Netherlands  
Singapore - Spain - Sweden - Switzerland - Taiwan - Thailand - United Kingdom - U.S.A.